



**SENSA**

collection 2025

## OUR HISTORY

Our Sensa story starts with Intersens Bikes & Parts BV. A family owned company located in the beautiful east of Holland. Here we have been building and developing high-quality sportive bikes for over 30 years.

Intersens has its roots in trading and developing different types of goods. After having originated in America during the 80's the first mountain bikes appeared in Holland. As a former amateur road cyclist Pieter Stiggelbout, founder of Intersens, noticed the potential. He traveled to Asia to purchase the first mountain bikes. In a time without e-mail or internet that was a huge challenge but in 1991 our first mountain bikes were imported. They were not branded Sensa yet though.

For us everything came together in 2005. This was the time to make our next move and express our personal passion for cycling and it's material with the launch of the Sensa brand! At first a small range of custom built and high quality road racing bikes was offered. In the years that followed our line-up grew. We developed custom built mountain bikes and trekking bikes to complement our race bike line-up. Using techniques we also used for our road race bikes.

## HANDBUILT IN HOLLAND

Our company and products keep evolving through innovation up to this day. From our first Sensa bike in 2005 till now all our bikes are built in Holland. If you order a custom bike, this will be built by one of our skilled mechanics, who builds your bike from start to finish.

## JOOP'S DREAM

**It's not the latest sportive bike people buy that matters most. It's the first!**

That first bike is the start of a richer life. To be more fit, more energetic, simply better than before. That bike gives you freedom to go anywhere you want with just your own power. Bikes are so versatile. Riding then never gets boring. There are always new routes to ride, new goals to reach. Whether you train hard in the hope of becoming a cycling professional or make a small ride just to enjoy the outdoors. The bike stands for freedom, every time you get on it! That's why we also care about the more affordable alloy models, and not just the high-end custom bikes. It's that first bike that can really spark the cycling-virus!

When I was young I already felt the need to change things on my bikes. To make it more "me". Combining stock components in a different way or adapting colors. The thrill of creating something new. Being young I was already asked about what colors I liked to see on next years new bikes. Growing up I got the chance to make this into my daily job. It still is very exciting to create a new frame, a component or color scheme. We know many riders share this passion for their bike. So we want to give them an experience in creating a truly personal custom bike.

***„My dream is to see everybody enjoy riding the Sensa of their dreams.“***

Joop Stiggelbout  
managing director

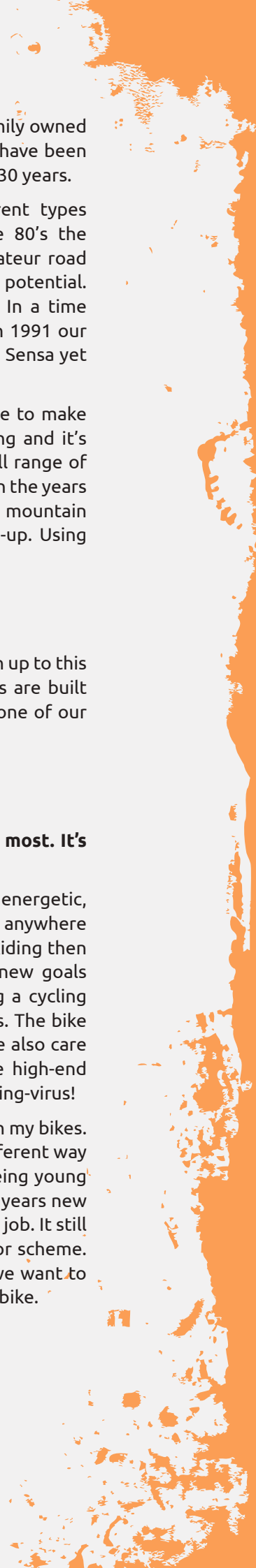

*Making excellent sportive bikes for excellent prices.  
So everybody can enjoy cycling!*

## Index

### Road Custom



### Road



### Gravel



### Mountain



### Trekking



### E-Bike



### Supra



### Clothing





## CUSTOM BUILT YOUR BIKE!

Our unique custom program gives you the opportunity to customize the bike to your preference. Because you are unique, the bike has to be unique! Multiple options from the best brands are available to really customize your new Sensa!

You start your custom journey at your Sensa dealer or on our brand new bike configurator at our website! Are you going for the Giulia Supremo, Giulia GF or Giulia Evo Integrale? Everything is possible! After this step you can choose between the best groupsets, wheel-sets, handlebars, tires and many more! You can find all the options on page 16 or in our new bike configurator on our brand new website!

After you customized your unique new bike we receive your configuration in our headquarters in the Netherlands. The warehouse collect all the parts for our team of skilled mechanics who are specially trained to build custom bikes. A single bike is built by a single mechanic who is proud to give his stamp of approval after finishing it. After sending it to your Sensa dealer you are ready to ride and break all your personal records!

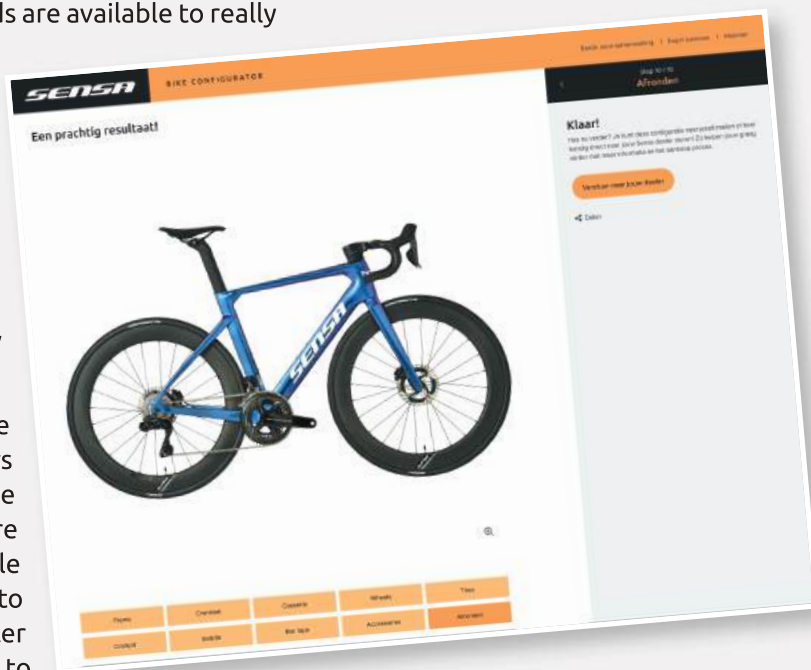

## SENSA KANJERS VOOR KANJERS CYCLING TEAM

Did you know we are the proud main-sponsor of the Sensa Kanjers voor Kanjers Cycling Team. This team plays a big role in the development of young talents with multiple national titles and riders who are now riding in the pro peloton. It's possible to customize your new bike like they did with the Giulia Supremo!



# GIULIA SUPREMO

## FASTER LIGHTER BETTER | SENSА GIULIA SUPREMO

It was our dream to create a bike that was faster, lighter and more comfortable than the Giulia Evo Integrale. Using the latest CFD-technology we found improvements on the Giulia Evo Intagrale and optimized each tube section. Lessons learned from the Giulia GF were applied to make the bike lighter and more comfortable.

We were able to improve drag reduction\* by 9.1 %. Giving you an advantage of 1,5% watt saving\*. Comfort\* was improved by 30%. Finally the weight dropped by 278 gram on the frame-kit (including seatpost, axles, dropouts etc). Numbers are nice, but the confirmation the testrides gave us was even better.

We present you our best roadbike ever!

## GIULIA SUPREMO, YOUR DREAMBIKE.

You are unique! And your bike should reflect that. So every custom Sensa is built to order specially for you by one of our mechanics. Our finest road bikes are offered as custom bikes with many different groupsets to choose from. Multiple options are available to really customize your new Sensa.

### LIMITED

Want to stand out from the crowd? We offer the Giulia Supremo in a special "Limited" color scheme. This color scheme is painted in limited numbers only, to make your already unique custom bike extra special.

**Frame** Generation 5 Full Carbon – EPS Moulding – CFD Optimized \ \ **Fork** Supra Full Carbon Monocoque – AIRflow 2 \ \ **Seatpost** Supra Race Line Carbon – Evo – 15mm offset

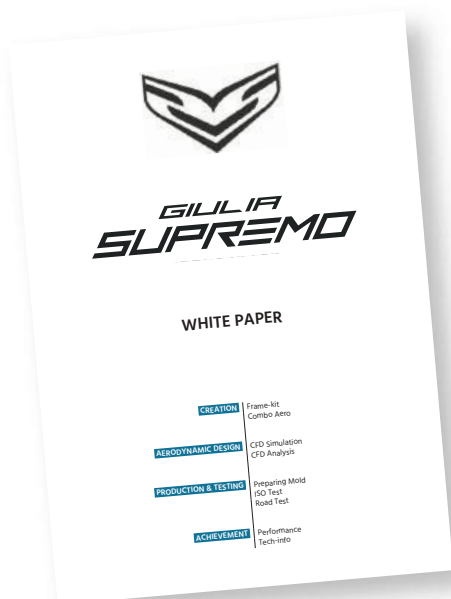

\*Read all the details in the White Paper on the website.

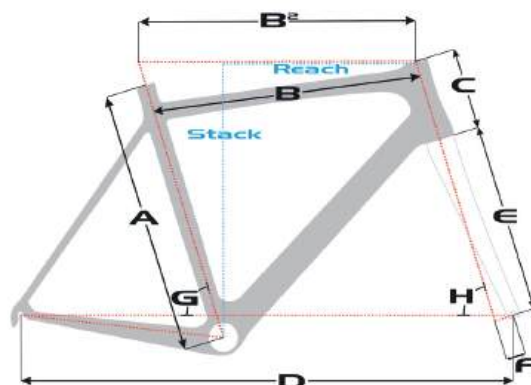



### Giulia Supremo

Size	A	B2	C	D	E	F	G	H	Reach	Stack
50cm	467mm	523mm	112mm	976mm	375mm	45mm	74,5°	72,0°	379mm	520mm
53cm	500mm	542mm	140mm	982mm	375mm	45mm	74,0°	73,0°	384mm	550mm
55cm	522mm	559mm	161mm	994mm	375mm	45mm	73,5°	73,0°	390mm	570mm
58cm	541mm	575mm	181mm	1005mm	375mm	45mm	73,0°	73,0°	395mm	590mm
61cm	564mm	591mm	201mm	1012mm	375mm	45mm	72,7°	73,5°	401mm	610mm



**Giulia Supremo**  
*Shiny Dark Brush*



Photo \* is with Full 105 2x12 Di2 groupset and options: Supra RFC 50 Elite Disc, Schwalbe Pro One Super Race Transparent Brown 28mm, Supra Combo Aero - Weight \* 8.1 KG (frame | 1025g & fork | 335g)



**Giulia Supremo**  
*Shades of Grey*  
**Limited**



Photo \* is with Full Ultegra 2x12 Di2 groupset and options: Supra RFC Premium Speed Disc Full Carbon, Vittoria Corsa Pro Skin-wall 28mm, Supra Combo Aero - Weight \* 7.8 KG (frame | 1025g & fork | 335g)

**Giulia Supremo**  
*Star Dust*  
**Limited**



Photo \* is with Full Dura Ace 2x12 Di2 groupset and options: Supra RFC Premium Speed Disc Full Carbon, Continental GP 5000 Black 28 mm, Supra Combo Aero - Weight \* 7.5 KG (frame | 1025g & fork | 335g)

# GIULIA GF

## THE ULTIMATE ALL-ROUNDER | SENSА GIULIA GF

Only 2 letters, G and F, but unlimited possibilities. This Generation Four of the original Giulia is still true to the initial idea of helping you realizing “gold” in your favorite Grand Fondo. But it does so much more. We designed it to be flexible in use. So you can run up to 32mm of rubber and have Great Fun on a gravel road, a cobblestone adventure or any road you would normally avoid. Find new routes and stay motivated through the winter to reach peak performance for your big goals in the summer. The newly designed rear triangle makes it our most comfortable road bike ever, so you will finish whatever you come up with, with a big smile. Of course the headtube and BB-stiffness boxes are ticked as always. We took the Aero-tubing profile of the Giulia Evo and improved on that. With EPS Moulding Techniques we create internal surfaces as smooth as the exterior, thus using less material to keep the weight low. Finally all the cables run into the headtube (except mechanical shifting), creating an ultra-clean look. The GF can be run with the Supra Combo Integrale or any regular stem. You decide! The complete overhaul of the geometry takes into account the bigger tires and makes it suitable for comfortable riding up to racing. In the end this is still a bike to Go Fast on!

**Frame** Generation 5 Full Carbon – EPS Moulding  
**Fork** Supra Full Carbon Monocoque - AIRflow \\  
**Seatpost** Supra Race Line GF Carbon – 27.2x370



## GIULIA GF, A TRUE RACER WHICH YOU WILL LOVE.

You are unique! And your bike should reflect that. So every custom Sensa is built to order specially for you by one of our mechanics. Our finest road bikes are offered as custom bikes with many different groupsets to choose from. Multiple options are available to really customize your new Sensa.

### LIMITED

Want to stand out from the crowd? We offer the Giulia GF in special “Limited” color schemes. This color scheme is painted in limited numbers only, to make your already unique custom bike extra special.

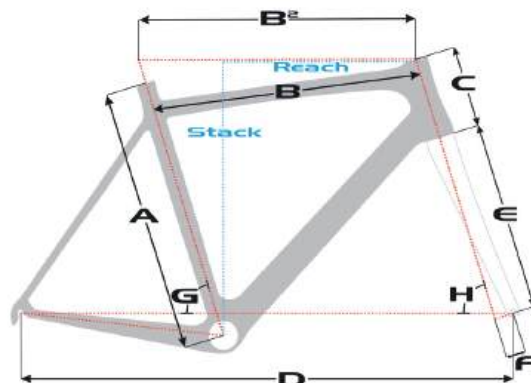



### Giulia GF

Size	A	B2	C	D	E	F	G	H	Reach	Stack
50cm	456mm	523mm	115mm	979mm	375mm	45mm	74,5°	71,7°	378mm	523mm
53cm	492mm	543mm	143mm	985mm	375mm	45mm	74,0°	72,7°	384mm	553mm
55cm	517mm	559mm	167mm	997mm	375mm	45mm	73,5°	72,7°	389mm	576mm
58cm	538mm	575mm	186mm	1004mm	375mm	45mm	73,0°	73,0°	393mm	595mm
61cm	564mm	591mm	207mm	1012mm	375mm	45mm	72,7°	73,5°	399mm	617mm

**Giulia GF**  
*Sparkle*  
*Black & Brush*



Photo \* is with Full 105 2x12 Di2 groupset and options: Supra RFC 35 Elite Disc, Vittoria Corsa Pro Skinwall 28mm, Supra Speed Line - Weight \* 8.0 KG (frame | 970g & fork | 355g)

**Giulia GF**  
*Space Gem*  
**Limited**



Photo \* is with Full Ultegra 2x12 Di2 groupset and options: Supra RFC 50 Elite Disc, Continental GP 5000 28mm Full Black, Supra Combo Integrale - Weight \* 7.5 KG (frame | 970g & fork | 355g)

**Giulia GF**  
*Lead on Black*  
**Limited**



Photo \* is with Full Ultegra 2x12 Di2 groupset and options: Supra RFC 50 Elite Disc, Continental GP 5000 28mm Full Black, Supra Combo Integrale - Weight \* 7.5 KG (frame | 970g & fork | 355g)

**Giulia GF**  
*Gold Brew Coffee*  
**Limited**



Photo \* is with Full Dura Ace 2x12 Di2 groupset and options: Supra RFC Premium SL Disc Full Carbon, Continental GP 5000 28mm Transparent Brown, Supra Combo Integrale - Weight \* 7.3 KG (frame | 970g & fork | 355g)

**GIULIA EVO INTEGRALE**



**THE NEED FOR SPEED  
SENSA GIULIA EVO INTEGRALE**

We took the Giulia Evo Disc to the next level. Bringing all the hoses internally and raising the headtube stiffness. To give you just that little advantage to be first at the finish line, or at the coffeehouse.

We designed the bike to perform optimal with 25mm tires. But it can take up to 30mm of rubber. So you can adapt the bike to ride on multiple surfaces. The rear-triangle is altered so the new 12speed groupsets have got additional clearance between chain and dropout. What has not been changed is the fast handling geometry of its predecessor and the smile it brings when you put the hammer down and enjoy the speed!

**GIULIA EVO INTEGRALE,  
BUILT TO GO FAST.**

You are unique! And your bike should reflect that. So every custom Sensa is built to order specially for you by one of our mechanics. Our finest road bikes are offered as custom bikes with many different groupsets to choose from. Multiple options are available to really customize your new Sensa.

**Frame** Generation 5 Full Carbon – Aero Integrale \ \ **Fork** Supra Full Carbon Monocoque AIRflow \ \ **Seatpost** Supra Race Line Carbon – Evo

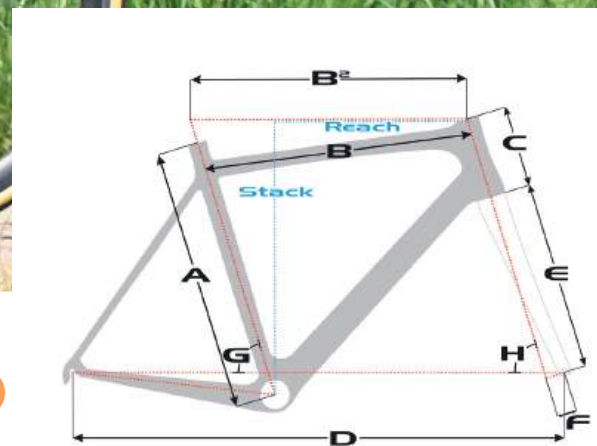

**Giulia Evo Integrale**

Size	A	B2	C	D	E	F	G	H	Reach	Stack
50cm	467mm	523mm	112mm	976mm	375mm	45mm	74,5°	72,0°	379mm	520mm
53cm	503mm	542mm	140mm	982mm	375mm	45mm	74,0°	73,0°	384mm	550mm
55cm	522mm	559mm	161mm	994mm	375mm	45mm	73,5°	73,0°	390mm	570mm
58cm	541mm	575mm	181mm	1005mm	375mm	45mm	73,0°	73,0°	395mm	590mm
61cm	564mm	591mm	201mm	1012mm	375mm	45mm	72,7°	73,5°	401mm	610mm

**Giulia Evo  
Integrale**  
*Matt Black & Hologram*



Photo \* is with Full Ultegra 2x12 Di2 groupset and options: Supra RFC 50 Elite Disc, Continental GP 5000 28 mm Full Black, Supra Combo Integrale - Weight \* 7.9 KG (frame | 1150g & fork | 355g)

**Giulia Evo  
Integrale**  
*Dark Sea  
Limited*



Photo \* is with Full 105 2x12 Di2 groupset and options: Supra RFC Premium SL Disc, Vittoria Corsa Pro Skinwall 28 mm, Supra Speed Line - Weight \* 8.2 KG (frame | 1150g & fork | 355g)

	Giulia Supremo Giulia GF Giulia Evo Int.	Giulia Supremo Giulia GF Giulia Evo Int.	Giulia Supremo Giulia GF Giulia Evo Int.	Giulia Evo Int.
	<b>FULL DURA ACE</b> <b>2X12 DI2 DISC</b> <b>R9270</b>	<b>FULL ULTEGRA</b> <b>2X12 DI2 DISC</b> <b>R8170</b>	<b>FULL 105</b> <b>2X12 DI2 DISC</b> <b>R7170</b>	<b>105</b> <b>2X12 DISC</b> <b>R7120</b>
<b>DRIVETRAIN</b>				
Compact - 50/34	STANDARD	STANDARD	STANDARD	STANDARD
Pro Compact - 52/36				
Casette 11-30	STANDARD	STANDARD	NO	NO
Casette 11-34			STANDARD	STANDARD
<b>WHEELS DISC-BRAKE</b>				
Supra RA Pro Disc	STANDARD	STANDARD	STANDARD	STANDARD
Supra RFC Premium Speed Disc Full Carbon				
Supra RFC Premium SL Disc Full Carbon				
Supra RFC 50 Elite Disc Full Carbon				
Supra RFC 35 Elite Disc Full Carbon				
DT Swiss ARC 1400 Dicut 50mm Full Carbon - <b>NEW</b>				
DT Swiss AR 1600 Spline 30				
DT Swiss A 1800 Spline 30				
<b>TIRES</b>				
Vittoria Rubino Pro Folding 28mm	STANDARD	STANDARD	STANDARD	STANDARD
Schwalbe Pro One Super Race Transparant Brown 28mm - <b>NEW</b>				
Vittoria Corsa Pro Skinwall 28mm - <b>NEW</b>				
Continental GP 5000 25mm Full Black				
Continental GP 5000 28mm Full Black				
Continental GP 5000 25mm Transparant Brown				
Continental GP 5000 28mm Transparant Brown				
Continental TPU innertube - <b>NEW</b>				
<b>SADDLES</b>				
Selle Italia Model X Superflow	STANDARD	STANDARD	STANDARD	STANDARD
Selle Italia Model X Superflow Comfort	YOUR CHOICE	YOUR CHOICE	YOUR CHOICE	YOUR CHOICE
Selle Italia X3 Boost Wide Open - Lady	YOUR CHOICE	YOUR CHOICE	YOUR CHOICE	YOUR CHOICE
San Marco Concor	YOUR CHOICE	YOUR CHOICE	YOUR CHOICE	YOUR CHOICE
San Marco Aspide Open	YOUR CHOICE	YOUR CHOICE	YOUR CHOICE	YOUR CHOICE
San Marco Shortfit Wide Open	YOUR CHOICE	YOUR CHOICE	YOUR CHOICE	YOUR CHOICE
<b>COCKPIT-SET</b>				
Supra Speed Line set	STANDARD	STANDARD	STANDARD	STANDARD
Slam-that-stem - Low stack adapter for regular stem				NO
Supra Combo Aero * : 1-Piece Integrated Stem-Bar Full Carbon * available only on Giulia Supremo				NO
Supra Combo Integrale: 1-Piece Integrated Stem-Bar Full Carbon				NO
Zipp SL 70 Ergo Handlebar Full Carbon for regular stem				
Handlebar Tape (see website)	YOUR CHOICE	YOUR CHOICE	YOUR CHOICE	YOUR CHOICE
<b>EXTRAS</b>				
Powermeter - Stages Left-sided				
Slideable Garmin holder to mount under Combo				
HideMyBell Raceday FI Garmin-holder for Combo				
Supra Full Carbon Waterbottle Cage V4 - Matt - per 2 pieces				
Elite Waterbottle Cage Custom Race Plus - P-o-B - per 2 pieces				
Shimano SPD-SL PD-R8000				
Shimano SPD-SL PD-RS500				





***road***

**Giulia GF  
Di2 Special**

S25R86GFSG



**frame** Generation 5 Full Carbon - EPS moulding - Full Internal \\ **fork** Supra full carbon monocoque - Airflow - Tapered 1.5 \\ **group** Full Shimano 105 Di2 Disc 2x12 - 50x34 + 11-34 - 105 hydraulic disc brakes \\ **seatpost** Carbon 27.2mm \\ **handlebar** Supra Speed Line \\ **stem** Supra Speed Line \\ **wheels** Supra RA Pro Disc \\ **tires** Schwalbe One Performance 28mm \\ **saddle** Selle Italia Model X Superflow \\ **sizes** 50-53-55-58-61cm \\ **color** Shiny Alpine Grey \\ **weight** 8.5KG (frame 970g & fork 350g)

**Giulia EVO  
Integrale  
105 2x12**

S25R85EIMB



**frame** Generation 5 Full Carbon - Aero Evo Disc - Full Internal \\ **fork** Supra full carbon monocoque - Airflow Evo Disc - Tapered 1.5 \\ **group** Full Shimano 105 Disc 2x12 - 50x34 + 11-34 - 105 hydraulic disc brakes \\ **seatpost** Supra Race Line Carbon Evo \\ **handlebar** Supra Speed Line \\ **stem** Supra Speed Line \\ **wheels** Supra RA Pro Disc \\ **tires** Schwalbe One Performance 28mm \\ **saddle** Selle San Marco Concor \\ **sizes** 50-53-55-58-61cm \\ **color** Matt Black \\ **weight** 8.8KG (frame 1180g & fork 355g)

## Giulia GF Pro 105 2x12

S25R84GFMB



**frame** Generation 5 Full Carbon - EPS moulding - Full Internal \\ **fork** Supra full carbon monocoque - Airflow - Tapered 1.5 \\ **group** Full Shimano 105 Disc 2x12 - 50x34 + 11-34 - 105 hydraulic disc brakes \\ **seatpost** Carbon 27.2mm \\ **handlebar** Supra Speed Line \\ **stem** Supra Speed Line \\ **wheels** Supra RA Pro Disc \\ **tires** Vittoria Rubino Folding 28mm \\ **saddle** Selle Italia Model X Superflow \\ **sizes** 50-53-55-58-61cm \\ **color** Matt Black & Titan \\ **weight** 8.5KG (frame 970g & fork 350g)

## Giulia GF Comp 105 2x12

S25R83GFSG



**frame** Generation 5 Full Carbon - EPS moulding - Full Internal \\ **fork** Supra full carbon monocoque - Airflow - Tapered 1.5 \\ **group** Full Shimano 105 Disc 2x12 - 50x34 + 11-34 - 105 hydraulic disc brakes \\ **seatpost** Carbon 27.2mm \\ **handlebar** Supra Comp Line \\ **stem** Supra Comp Line \\ **wheels** Supra RA Comp Disc \\ **tires** Schwalbe Lugano 28mm \\ **saddle** Selle Italia Model X Superflow \\ **sizes** 50-53-55-58-61cm \\ **color** Shiny Lead Grey \\ **weight** 8.7KG (frame 970g & fork 350g)

**Romagna RS**  
**105 2x12**

S25R77RRSG



**frame** Lite aluminium 6061 - 2x butted - Hydroformed - Smooth - Flat mount - E-thru 12mm - Internal cable routing - Tapered 1.5 \\ **fork** Supra Full carbon S3 - Flat mount - E-thru 12mm - Tapered 1.5 \\ **group** Full Shimano 105 Disc 2x12 - 50x34 + 11-34 - 105 hydraulic disc brakes \\ **seatpost** Supra Comp Line 31.6mm \\ **handlebar** Supra Comp Line \\ **stem** Supra Comp Line \\ **wheels** Supra RA Comp Disc \\ **tires** Vittoria Zaffiro Pro 30mm Folding \\ **saddle** Selle Italia Model X Superflow \\ **sizes** S51 - M55 - L58 - XL62 \\ **color** Shiny Shadow Sea \\ **weight** 9.6KG

**Romagna Disc**  
**105 2x12**

S25R76RDSR



**frame** Lite aluminium 6061 - 2x butted - Hydroformed - Flat mount - E-thru 12mm - Internal cable routing - Tapered 1.5 \\ **fork** Supra Full carbon S2 - Flat mount - E-thru 12mm - Tapered 1.5 \\ **group** Full Shimano 105 Disc 2x12 - 50x34 + 11-34 - 105 hydraulic disc brakes \\ **seatpost** Supra Comp Line 31.6mm \\ **handlebar** Supra Comp Line \\ **stem** Supra Comp Line \\ **wheels** Supra RA Comp Disc \\ **tires** Schwalbe Lugano 28mm \\ **saddle** Selle Italia Model X Superflow \\ **sizes** S51 - M55 - L58 - XL62 \\ **color** Shiny Racing Red \\ **weight** 9.7KG

## Romagna Disc SLE 2x12

S25R75RDMB



**frame** Lite aluminium 6061 - 2x butted - Hydroformed - Flat mount - E-thru 12mm - Internal cable routing - Tapered 1.5 \\ **fork** Supra Full carbon S2 - Flat mount - E-thru 12mm - Tapered 1.5 \\ **group** Shimano 105 Disc 2x12 - FC-RS520 50x34 + 11-34 - 105 hydraulic disc brakes \\ **seatpost** Supra Comp Line 31.6mm \\ **handlebar** Supra Comp Line \\ **stem** Supra Comp Line \\ **wheels** Supra RA Comp Disc \\ **tires** Schwalbe Lugano 28mm \\ **saddle** Selle Italia Model X Superflow \\ **sizes** S51 - M55 - L58 - XL62 \\ **color** Matt Black + Dark Brush \\ **weight** 10.1KG

## Romagna Disc Tiagra

S25R74RDSG



**frame** Lite aluminium 6061 - 2x butted - Hydroformed - Flat mount - E-thru 12mm - Internal cable routing - Tapered 1.5 \\ **fork** Supra Full carbon S2 - Flat mount - E-thru 12mm - Tapered 1.5 \\ **group** Full Shimano Tiagra Disc 2x10 - 50x34 + 11-34 - Tiagra hydraulic disc brakes \\ **seatpost** Supra Comp Line 31.6mm \\ **handlebar** Supra Comp Line \\ **stem** Supra Comp Line \\ **wheels** Supra RA Comp Disc \\ **tires** Vittoria Zaffiro 28mm \\ **saddle** Selle Italia Model X Superflow \\ **sizes** S51 - M55 - L58 - XL62 \\ **color** Shiny Thunder Grey \\ **weight** 10.1KG

## Emilia Lady RS 105 2x12

S25R77ERSG

**frame** Lite aluminium 6061 - 2x butted - Hydroformed - Smooth - Flat mount - E-thru 12mm - Internal cable routing - Tapered 1.5 \\ **fork** Supra Full carbon S3 - Flat mount - E-thru 12mm - Tapered 1.5 \\ **group** Full Shimano 105 Disc 2x12 - 50x34 + 11-34 - 105 hydraulic disc brakes \\ **seatpost** Supra Comp Line 31.6mm \\ **handlebar** Supra Comp Line \\ **stem** Supra Comp Line \\ **wheels** Supra RA Comp Disc \\ **tires** Vittoria Zaffiro Pro 30mm Folding \\ **saddle** Selle Italia Model X Superflow Comfort \\ **sizes** XS48 - S51 - M54 - L56 \\ **color** Shiny Shadow Sea \\ **weight** 9.6KG



## Emilia Lady Disc 105 2x12

S25R76EDSG

**frame** Lite aluminium 6061 - 2x butted - Hydroformed - Flat mount - E-thru 12mm - Internal cable routing - Tapered 1.5 \\ **fork** Supra Full carbon S2 - Flat mount - E-thru 12mm - Tapered 1.5 \\ **group** Full Shimano 105 Disc 2x12 - 50x34 + 11-34 - 105 hydraulic disc brakes \\ **seatpost** Supra Comp Line 31.6mm \\ **handlebar** Supra Comp Line \\ **stem** Supra Comp Line \\ **wheels** Supra RA Comp Disc \\ **tires** Schwalbe Lugano 28mm \\ **saddle** Selle Italia Model X Superflow Comfort \\ **sizes** XS48 - S51 - M54 - L56 \\ **color** Shiny Green-like Grey \\ **weight** 9.8KG



## Emilia Lady Disc Tiagra

S25R74EDSP

**frame** Lite aluminium 6061 - 2x butted - Hydroformed - Flat mount - E-thru 12mm - Internal cable routing - Tapered 1.5 \\ **fork** Supra Full carbon S2 - Flat mount - E-thru 12mm - Tapered 1.5 \\ **group** Full Shimano Tiagra Disc 2x10 - 50x34 + 11-34 - Tiagra hydraulic disc brakes \\ **seatpost** Supra Comp Line 31.6mm \\ **handlebar** Supra Comp Line \\ **stem** Supra Comp Line \\ **wheels** Supra RA Comp Disc \\ **tires** Vittoria Zaffiro 28mm \\ **saddle** Selle Italia Model X3 Lady Boost \\ **sizes** XS48 - S51 - M54 - L56 \\ **color** Shiny Imperial Purple \\ **weight** 10.3KG





***gravel***

**Giulia Gravel  
Elite GRX  
+ Carbon Wheels**

S25G89GGMB



**frame** Generation 5 Full Carbon - EPS moulding \\ **fork** Supra full carbon XD - Flat mount - E-thru 12mm - Tapered 1.5 \\ **group** Shimano GRX 2x12 - RX-820 Front and Rear derailleurs - FC-RX610 46x30 + CS 11-34 - Hydraulic disc brakes \\ **seatpost** Carbon 27.2mm \\ **handlebar** Supra X Line Flare \\ **stem** Supra X Line \\ **wheels** Supra GFC Elite TLR Carbon \\ **tires** Schwalbe G-One R Evo, Super Race 40mm \\ **saddle** Selle Italia Model X Superflow \\ **sizes** S-M-L-XL \\ **color** Matt Black & Sand \\ **weight** 8.9KG

**Giulia Gravel has road and cyclocross in its DNA.**

But with a geometry that's more comfortable. The longer reach and higher stack combined with a slacker headtube offers more control and relaxed steering. You can mount mudguards, a toptube storage, and 3 large water bottles if you like. You can fit up to 47mm of rubber.

The bike is super easy-to-service. So you can go explore, commute or simply put the hammer down anywhere you are.

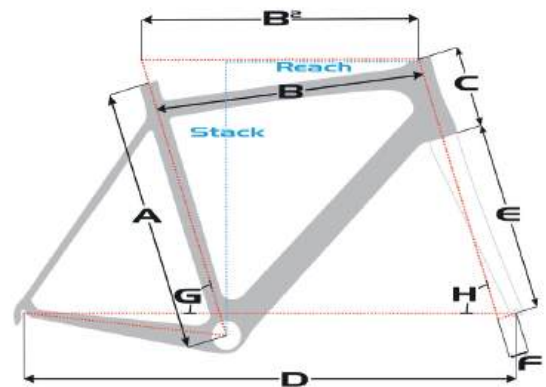

**Giulia Gravel**

Size	A	B2	C	D	E	F	G	H	Reach	Stack
S	480mm	547mm	140mm	1019mm	395mm	50mm	73,5°	71,2°	380mm	564mm
M	525mm	557mm	156mm	1027mm	395mm	50mm	73,5°	71,5°	385mm	580mm
L	570mm	573mm	178mm	1041mm	395mm	50mm	73,5°	71,8°	395mm	602mm
XL	600mm	589mm	198mm	1055mm	395mm	50mm	73,5°	72,0°	405mm	622mm



## Giulia Gravel Elite GRX

S25G88GGMB



**frame** Generation 5 Full Carbon - EPS moulding \\ **fork** Supra full carbon XD - Flat mount - E-thru 12mm - Tapered 1.5 \\ **group** Shimano GRX 2x12 - RX-820 Front and Rear derailleurs - FC-RX610 46x30 + CS 11-34 - Hydraulic disc brakes \\ **seatpost** Carbon 27.2mm \\ **handlebar** Supra X Line Flare \\ **stem** Supra X Line \\ **wheels** Supra GA Elite TLR \\ **tires** Vittoria Terreno Dry folding 40mm \\ **saddle** Selle Italia Model X Superflow \\ **sizes** S-M-L-XL \\ **color** Matt Black & Sand \\ **weight** 9.1KG

## Giulia Gravel Pro GRX

S25G87GGSG



**frame** Generation 5 Full Carbon - EPS moulding \\ **fork** Supra full carbon XD - Flat mount - E-thru 12mm - Tapered 1.5 \\ **group** Shimano GRX 2x12 - RX-820 Front and Rear derailleurs - FC-RX610 46x30 + CS 11-34 - Hydraulic disc brakes \\ **seatpost** Alloy 27.2mm \\ **handlebar** Supra X Line Flare \\ **stem** Supra X Line \\ **wheels** Supra RA Comp Disc \\ **tires** Vittoria Terreno Dry folding 40mm \\ **saddle** Selle Italia Model X Superflow \\ **sizes** S-M-L-XL \\ **color** Shiny Dark Sea \\ **weight** 9.3KG

**Romagna Gravel  
SE GRX 2x12**

S25G79RGSB



**frame** Lite aluminium 6061 - 2x butted - Hydroformed - Smooth - Flat mount - E-thru 12mm - Internal cable routing - Tapered 1.5 \\ **fork** Supra full carbon XD - Flat mount - E-thru 12mm - Tapered 1.5 \\ **group** Shimano GRX 2x12 - RX-820 Front and Rear derailleurs - FC-RX610 46x30 + CS 11-34 - Hydraulic disc brakes \\ **seatpost** Supra Comp Line 31.6mm \\ **handlebar** Supra Comp Line Gravel - Flared \\ **stem** Supra Comp Line \\ **wheels** Supra RA Comp Disc \\ **tires** Vittoria Terreno Dry folding 47mm \\ **saddle** Selle Italia Model X Superflow \\ **sizes** 51-55-58-61cm \\ **color** Shiny Black + Olive Grey \\ **weight** 10.3KG

**Romagna Gravel  
GRX 2x12**

S25G78RGMB



**frame** Lite aluminium 6061 - 2x butted - Hydroformed - Flat mount - E-thru 12mm - Internal cable routing - Tapered 1.5 \\ **fork** Supra full carbon XD - Flat mount - E-thru 12mm - Tapered 1.5 \\ **group** Shimano GRX 2x12 - RX-820 Front and Rear derailleurs - FC-RX610 46x30 + CS 11-34 - Hydraulic disc brakes \\ **seatpost** Supra Comp Line 31.6mm \\ **handlebar** Supra Comp Line Gravel - Flared \\ **stem** Supra Comp Line \\ **wheels** Supra RA Comp Disc \\ **tires** Vittoria Terreno Dry folding 40mm \\ **saddle** Selle Italia Model X Superflow \\ **sizes** 51-55-58-61cm \\ **color** Matt Black + Pearl Olive Green \\ **weight** 10.0KG



***mountainbike***

**Fiori Evo Elite  
DT Edition**

S25M59FEMG



**frame** Generation 5 Full Carbon - Boost-148 - Thru-Axle - Dropper ready - Tapered 1.5 \\ **fork** RockShox SID SL - DebonAir - 100mm travel - Boost - Oneloc - Tapered 1.5 \\ **group** Shimano XT 1x12 - 34T + 10-51 - CS & CN M7100 - XT hydraulic disc brakes \\ **seatpost** Supra X Line 30.9mm \\ **handlebar** Supra X Line - 720mm + 5mm rise \\ **stem** Supra X Line \\ **wheels** DT Swiss XRC 1501 Spline Carbon \\ **tires** Vittoria Barzo XC-Trail folding TLR 2.25 \\ **saddle** Selle Italia Model X Superflow \\ **sizes** 29er | 17-19-21" \\ **color** Stone Titan \\ **weight** 10.0KG

**Fiori Evo Elite  
Stone Titan  
Limited**

S25M58FEMG



**frame** Generation 5 Full Carbon - Boost-148 - Thru-Axle - Dropper ready - Tapered 1.5 \\ **fork** RockShox SID SL - DebonAir - 100mm travel - Boost - Oneloc - Tapered 1.5 \\ **group** Shimano XT 1x12 - 34T + 10-51 - CS & CN M7100 - XT hydraulic disc brakes \\ **seatpost** Supra X Line 30.9mm \\ **handlebar** Supra X Line - 720mm + 5mm rise \\ **stem** Supra X Line \\ **wheels** Supra MA Elite 23-TLR - Tubeless ready \\ **tires** Vittoria Barzo XCR folding TLR 2.25 \\ **saddle** Selle Italia Model X Superflow \\ **sizes** 29er | 17-19-21" \\ **color** Stone Titan \\ **weight** 10.6KG

## Fiori Evo Elite Star Dust Limited

S25M58FESB



**frame** Generation 5 Full Carbon - Boost-148 - Thru-Axle - Dropper ready - Tapered 1.5 \\ **fork** RockShox SID SL - DebonAir - 100mm travel - Boost - Oneloc - Tapered 1.5 \\ **group** Shimano XT 1x12 - 34T + 10-51 - CS & CN M7100 - XT hydraulic disc brakes \\ **seatpost** Supra X Line 30.9mm \\ **handlebar** Supra X Line - 720mm + 5mm rise \\ **stem** Supra X Line \\ **wheels** Supra MA Elite 23-TLR - Tubeless ready \\ **tires** Vittoria Barzo XC-Trail folding TLR 2.25 \\ **saddle** Selle Italia Model X Superflow \\ **sizes** 29er | 17-19-21" \\ **color** Shiny Star Dust \\ **weight** 10.6KG

## Fiori Evo Elite

S25M58FERB



**frame** Generation 5 Full Carbon - Boost-148 - Thru-Axle - Dropper ready - Tapered 1.5 \\ **fork** RockShox SID SL - DebonAir - 100mm travel - Boost - Oneloc - Tapered 1.5 \\ **group** Shimano XT 1x12 - 34T + 10-51 - CS & CN M7100 - XT hydraulic disc brakes \\ **seatpost** Supra X Line 30.9mm \\ **handlebar** Supra X Line - 720mm + 5mm rise \\ **stem** Supra X Line \\ **wheels** Supra MA Elite 23-TLR - Tubeless ready \\ **tires** Vittoria Barzo XCR folding TLR 2.25 \\ **saddle** Selle Italia Model X Superflow \\ **sizes** 29er | 17-19-21" \\ **color** Red-on-Black \\ **weight** 10.6KG

**Fiori Evo  
Pro**

S25M56FPSS



**frame** Generation 5 Full Carbon - Boost-148 - Thru-Axle - Dropper ready - Tapered 1.5 \\ **fork** RockShox Recon RL - Air - 100mm travel - Boost - Oneloc - Tapered 1.5 \\ **group** Shimano XT 1x12 - FC-MT510 34T + 10-51 - CS & CN M7100 - MT410 hydraulic disc brakes \\ **seatpost** Supra X Line 30.9mm \\ **handlebar** Supra X Line - 720mm + 5mm rise \\ **stem** Supra X Line \\ **wheels** Supra MA Pro \\ **tires** Vittoria Saguardo folding 2.25 \\ **saddle** Selle Italia Model X Superflow \\ **sizes** 29er | 17-19-21" \\ **color** Shiny Stellar Silver \\ **weight** 12.2KG

**Fiori Evo  
SLE**

S25M52FSMB



**frame** Generation 5 Full Carbon - Boost-148 - Thru-Axle - Dropper ready - Tapered 1.5 \\ **fork** RockShox Judy Silver TK - Air - 100mm travel - Boost - Poploc - Tapered 1.5 \\ **group** Shimano Deore 1x12 - FC-MT511 32T + 10-51 - XT rear derailleur - MT410 hydraulic disc brakes \\ **seatpost** Supra X Line 30.9mm \\ **handlebar** Supra X Line - 720mm + 5mm rise \\ **stem** Supra X Line \\ **wheels** Supra MA Pro \\ **tires** Schwalbe Rapid Rob Bronze Skin 2.25 \\ **saddle** Selle Italia Model X Superflow \\ **sizes** 29er | 17-19-21" \\ **color** Dark Brush \\ **weight** 12.3KG

## Merano XC Pro

S25M46MPSB



**frame** Ultralite aluminium 6066 - 3x butted - Hydroformed - Smooth - Boost-148 - Thru-Axle - Tapered 1.5 \\ **fork** RockShox Recon RL - Air - 100mm travel - Boost - Oneloc - Tapered 1.5 \\ **group** Shimano XT 1x12 - FC-MT510 34T + 10-51 - CS & CN M7100 - MT410 hydraulic disc brakes \\ **seatpost** Supra X Line 31.6mm \\ **handlebar** Supra X Line - 720mm + 5mm rise \\ **stem** Supra X Line \\ **wheels** Supra MA Pro \\ **tires** Schwalbe Racing Ralph Performance 2.25 \\ **saddle** Selle Italia Model X Superflow \\ **sizes** 29er | 17-19-21" \\ **color** Shiny Midnight Blue \\ **weight** 12.5KG

## Merano XC Race

S25M44MRSG



**frame** Ultralite aluminium 6066 - 3x butted - Hydroformed - Smooth - Boost-148 - Thru-Axle - Tapered 1.5 \\ **fork** RockShox Judy Silver TK - Air - 100mm travel - Boost - Poploc - Tapered 1.5 \\ **group** Shimano XT 1x12 - FC-MT511 32T + 10-51 - CS & CN M6100 - Shimano hydraulic disc brakes \\ **seatpost** Supra X Line 31.6mm \\ **handlebar** Supra X Line - 720mm + 5mm rise \\ **stem** Supra X Line \\ **wheels** Supra MA Pro \\ **tires** Schwalbe Smart Sam Bronze 2.35 \\ **saddle** Selle Italia Model X Superflow \\ **sizes** 29er | 17-19-21" \\ **color** Shiny Flat Grey \\ **weight** 13.1KG

**Merano EVO  
SLE**

S25M42MSMG



**frame** Ultralite aluminium 6066 - 3x butted - Hydroformed - Boost-148 - Thru-Axle - Tapered 1.5 \\ **fork** RockShox Judy Silver TK - Air - 100mm travel - Boost - Poploc - Tapered 1.5 \\ **group** Shimano Deore 1x12 - FC-MT511 32T + 10-51 - XT rear derailleur - Shimano hydraulic disc brakes \\ **seatpost** Supra Comp Line 31.6mm \\ **handlebar** Supra Comp Line \\ **stem** Supra Comp Line \\ **wheels** Supra MA Pro \\ **tires** Schwalbe Rapid Rob K-guard 2.25 \\ **saddle** Supra Comp XC \\ **sizes** 29er | 17-19-21" \\ **color** Matt Dusk Grey \\ **weight** 13.1KG

**Merano Power  
Pro**

S25E49MPMG



**frame** Lite aluminium 6061 - 2x butted - Hydroformed - Boost-148 - Thru-Axle - Tapered 1.5 - STEPS optimized \\ **fork** RockShox Judy Silver TK - E-MTB - Air - 120mm travel - Boost - Lockout - Tapered 1.5 \\ **group** Shimano Cues 6000 1x10 - 34T + 11-48 - MT400 hydraulic disc brakes \\ **seatpost** Supra X Line 30.9mm \\ **handlebar** Uno heavy duty - 740mm \\ **stem** Uno heavy duty - 45mm \\ **wheels** Supra MA Pro \\ **tires** Vittoria e-Agarro Trail TNT folding 2.35 \\ **saddle** Selle Italia X3 Boost \\ **battery** Shimano STEPS BT-E8010 - 504Wh \\ **drive unit** Shimano STEPS DU-E7000 (60Nm - 250W) \\ **display** Shimano STEPS SC-E7000 \\ **charger** Shimano STEPS EC-E6002 \\ **sizes** 29er | 16,5-18-21" \\ **color** Matt Dusk Grey \\ **weight** 20.5KG (incl. battery - 2.6KG)



## Livigno XC XT-edition

S25M38LXSB



**frame** Lite aluminium 6061 - 2x butted - Hydroformed - Boost - Internal cable routing - Tapered 1.5 \\ **fork** SR Suntour XCR - Air - 100mm travel - Remote LockOut - Stealth \\ **group** Shimano Deore 1x12 - FC-MT511 32T + 10-51 - XT rear derailleur - Shimano hydraulic disc brakes \\ **seatpost** Supra Comp Line 31.6mm \\ **handlebar** Supra Comp Line \\ **stem** Supra Comp Line \\ **wheels** Supra MA Comp \\ **tires** Schwalbe Smart Sam Bronze 2.35 \\ **saddle** Supra Comp XC \\ **sizes** 29er | 17-19-21" \\ **color** Shiny Black \\ **weight** 13.5KG

## Livigno Evo Deore 12

S25M36LCSG



**frame** Lite aluminium 6061 - 2x butted - Hydroformed - Boost - Internal cable routing - Tapered 1.5 \\ **fork** SR Suntour XCR - Air - 100mm travel - Remote LockOut \\ **group** Shimano Deore 1x12 - FC-MT511 32T + 10-51 - Shimano hydraulic disc brakes \\ **seatpost** Supra Comp Line 31.6mm \\ **handlebar** Supra Comp Line \\ **stem** Supra Comp Line \\ **wheels** Supra MA Comp \\ **tires** Schwalbe Rapid Rob K-guard 2.25 \\ **saddle** Supra Comp XC \\ **sizes** 29er | 15-17-19-21" \\ **color** Shiny Hazy Grey \\ **weight** 13.6KG

**Livigno Evo  
C11**

S25M35LCMB



**frame** Lite aluminium 6061 - 2x butted - Hydroformed - Boost - Internal cable routing - Tapered 1.5 \\ **fork** SR Suntour X1-XCR - Coil - 100mm travel - Remote LockOut \\ **group** Shimano Cues 1x11 - 32T + 11-50 - Shimano hydraulic disc brakes \\ **seatpost** Supra Comp Line 31.6mm \\ **handlebar** Supra Comp Line \\ **stem** Supra Comp Line \\ **wheels** Supra MA Comp \\ **tires** Vittoria Barzo 2.25 \\ **saddle** Supra Comp XC \\ **sizes** 29er | 15-17-19-21" \\ **color** Matt Black + Dark Brush \\ **weight** 13.7KG

**Livigno Evo  
C9**

S25M31LCSO



**frame** Lite aluminium 6061 - 2x butted - Hydroformed - Boost - Internal cable routing - Tapered 1.5 \\ **fork** SR Suntour XCM - Coil - 100mm travel - LockOut \\ **group** Shimano Cues 1x9 - 32T + 11-46 - Shimano hydraulic disc brakes \\ **seatpost** Supra Comp Line 31.6mm \\ **handlebar** Supra Comp Line \\ **stem** Supra Comp Line \\ **wheels** Supra MA Comp \\ **tires** Vittoria Barzo 2.25 \\ **saddle** Supra Comp XC \\ **sizes** 29er | 15-17-19-21" \\ **color** Shiny Pearl Orange \\ **weight** 13.8KG



***trekking***

**Travel Lite Disc 2x10** S25T18TLMG

<b>frame</b>	Ultralite aluminium 6066 - 3x butted - Hydroformed - Smooth finish - Tapered 1.5
<b>fork</b>	Supra Superlite Alloy Disc - Tapered 1.5
<b>group</b>	Shimano Cues 2x10 - LinkGlide - Shimano hydraulic disc brakes
<b>seatpost</b>	Supra Comp Line 27.2
<b>handlebar</b>	Supra Comp Line
<b>stem</b>	Satori UP3 - Adjustable
<b>lights</b>	Shimano hub dynamo - AXA Blueline30 + AXA Juno
<b>wheels</b>	Ryde DP19 + Shimano hubs
<b>tires</b>	Schwalbe Energizer Active Plus 40-622
<b>saddle</b>	Selle Royal Essenza
<b>sizes</b>	50-53-55-58-61cm
<b>color</b>	Shiny-on-Matt Graphite
<b>weight</b>	14.3KG



## Superlite Disc S25T17SLSG

<b>frame</b>	Ultralite aluminium 6066 - 3x butted - Hydroformed - Smooth finish - Tapered 1.5
<b>fork</b>	Supra Full Carbon SL Disc - Tapered 1.5
<b>group</b>	Shimano Cues 2x9 - LinkGlide - Shimano hydraulic disc brakes
<b>seatpost</b>	Supra Base Line
<b>handlebar</b>	Satori Noirette
<b>stem</b>	Satori UP3 - Adjustable
<b>lock</b>	AXA Defender RL
<b>lights</b>	AXA NOX Sport + AXA Juno
<b>wheels</b>	Ryde DP19 + Shimano hubs
<b>tires</b>	Schwalbe Road Cruiser 37-622
<b>saddle</b>	Selle Royal Nuvola
<b>sizes</b>	Lady 51-56cm Gent 56-61cm
<b>color</b>	Shiny Hazy Grey
<b>weight</b>	13.7KG



**Cross Sport Disc Limited** S25T15CSMB

<b>frame</b>	Lite aluminium 6061 - 2x butted - Hydroformed
<b>fork</b>	SR Suntour NCX-NX1 Lite - LockOut
<b>group</b>	Shimano Cues 2x9 - LinkGlide - Shimano hydraulic disc brakes
<b>seatpost</b>	Supra Base Line
<b>handlebar</b>	Uno Alloy
<b>stem</b>	Uno Alloy - Adjustable
<b>lights</b>	Shimano hub dynamo - AXA Blueline30 + Axa Spark
<b>wheels</b>	Ryde DP19 + Shimano hubs
<b>tires</b>	Schwalbe Road Cruiser 37-622
<b>saddle</b>	Selle Royal Freeway
<b>sizes</b>	Lady 48-53cm Gent 56-61cm
<b>color</b>	Matt Black
<b>weight</b>	16.2KG



## Superlite 24 S25T13STSS

<b>frame</b>	Ultralite aluminium 6066 - 3x butted - Hydroformed
<b>fork</b>	Supra carbon
<b>group</b>	Shimano Acera 3x8
<b>seatpost</b>	Supra Base Line
<b>handlebar</b>	Uno Alloy
<b>stem</b>	Uno Alloy - Adjustable
<b>lock</b>	AXA Defender RL
<b>lights</b>	Safety LED + AXA Spark
<b>wheels</b>	Ryde X-plorer + Shimano hubs
<b>tires</b>	Schwalbe Road Cruiser 37-622
<b>saddle</b>	Selle Royal Nuvola
<b>sizes</b>	Lady 50-55cm Gent 55-61cm
<b>color</b>	Shiny Speedy Silver
<b>weight</b>	13.7KG



**Cintura Belt-Drive Limited Grey** S25T12CBL2

<b>frame</b>	Lite aluminium 6061 - 2x butted - Hydroformed - Smooth finish - Tapered 1.5
<b>fork</b>	Supra Superlite Alloy Disc - Tapered 1.5
<b>group</b>	Shimano Alfine-8 - Gates CDN belt drive - Shimano hydraulic disc brakes
<b>seatpost</b>	Supra Base Line
<b>handlebar</b>	Uno Alloy
<b>stem</b>	Uno Alloy - Adjustable
<b>lock</b>	AXA Defender RL
<b>lights</b>	Shimano hub dynamo - AXA Blueline30 + AXA Juno Steady
<b>wheels</b>	Ryde DP19 + Shimano hubs
<b>tires</b>	Schwalbe Road Cruiser 37-622
<b>saddle</b>	Selle Royal Freeway
<b>sizes</b>	Lady 50-55cm Gent 55-61cm
<b>color</b>	Shiny Flat grey
<b>weight</b>	14.9KG





## Cintura Belt-Drive Limited Green S25T12CBL1

<b>frame</b>	Lite aluminium 6061 - 2x butted - Hydroformed - Smooth finish - Tapered 1.5
<b>fork</b>	Supra Superlite Alloy Disc - Tapered 1.5
<b>group</b>	Shimano Alfine-8 - Gates CDN belt drive - Shimano hydraulic disc brakes
<b>seatpost</b>	Supra Base Line
<b>handlebar</b>	Uno Alloy
<b>stem</b>	Uno Alloy - Adjustable
<b>lock</b>	AXA Defender RL
<b>lights</b>	Shimano hub dynamo - AXA Blueline30 + AXA Juno Steady
<b>wheels</b>	Ryde DP19 + Shimano hubs
<b>tires</b>	Schwalbe Road Cruiser 37-622
<b>saddle</b>	Selle Royal Freeway
<b>sizes</b>	Lady 50-55cm Gent 55-61cm
<b>color</b>	Shiny Lake Green (Lady) Shiny Emerald Green (Gent)
<b>weight</b>	14.9KG



**Cintura Belt-Drive** S25T12CBMB

- frame** Lite aluminium 6061 - 2x butted - Hydroformed - Smooth finish - Tapered 1.5
- fork** Supra Superlite Alloy Disc - Tapered 1.5
- group** Shimano Alfine-8 - Gates CDN belt drive - Shimano hydraulic disc brakes
- seatpost** Supra Base Line
- handlebar** Uno Alloy
- stem** Uno Alloy - Adjustable
- lock** AXA Defender RL
- lights** Shimano hub dynamo - AXA Blueline30 + AXA Juno Steady
- wheels** Ryde DP19 + Shimano hubs
- tires** Schwalbe Road Cruiser 37-622
- saddle** Selle Royal Freeway
- sizes** Lady 50-55cm  
Gent 55-61cm
- color** Matt Black + Dark Brush
- weight** 14.9KG



## Cintura Belt-Drive LTD7 S25T11CBMB

<b>frame</b>	Lite aluminium 6061 - 2x butted - Hydroformed - Smooth finish - Tapered 1.5
<b>fork</b>	Supra Superlite Alloy Disc - Tapered 1.5
<b>group</b>	Shimano Nexus-7 - Gates CDN belt drive - Shimano hydraulic disc brakes
<b>seatpost</b>	Supra Base Line
<b>handlebar</b>	Uno Alloy
<b>stem</b>	Uno Alloy - Adjustable
<b>lock</b>	AXA Defender RL
<b>lights</b>	Shimano hub dynamo - AXA Blueline30 + AXA Juno Steady
<b>wheels</b>	Ryde DP19 + Shimano hubs
<b>tires</b>	Schwalbe Road Cruiser 37-622
<b>saddle</b>	Selle Royal Wave
<b>sizes</b>	Lady 50-55cm Gent 55-61cm
<b>color</b>	Matt Black + Dark Brush
<b>weight</b>	15.1KG



**Treviso N-7** S25T10TNSG

<b>frame</b>	Lite aluminium 6061 - 2x butted - Tapered 1.5
<b>fork</b>	Supra Superlite Alloy - Tapered 1.5
<b>group</b>	Shimano Nexus-7 - Shimano rollerbrakes
<b>seatpost</b>	Supra Base Line
<b>handlebar</b>	Uno Alloy
<b>stem</b>	Uno Alloy - Adjustable
<b>lock</b>	AXA Defender RL
<b>lights</b>	Shimano hub dynamo - AXA Blueline30 + AXA Spark
<b>wheels</b>	Ryde X-plorer + Shimano hubs
<b>tires</b>	Schwalbe Road Cruiser 37-622
<b>saddle</b>	Selle Royal Freeway
<b>sizes</b>	Lady 51-56cm Gent 56-61cm
<b>color</b>	Shiny Lead Grey
<b>weight</b>	16.6KG





***e-bike***

**Cintura Power Premium 630** S25E08CPMB

- frame** Lite aluminium 6061 - In-tube battery - Tapered 1.5
- fork** SR Suntour NCX32 Lock-out - Stealth
- group** Shimano Alfine-8 - Shimano hydraulic disc brakes - Gates CDX belt + CDC drive
- seatpost** Supra Comp Line 27.2
- handlebar** Supra Comp Line 68cm + 15mm rise
- stem** Satori UP2+ Adjustable
- lock** Axa Block XXL
- lights** Trelock Veo 50 lux + AXA Juno - E-bike powered
- wheels** Ryde DP19 + Shimano hubs
- tires** Schwalbe Super Moto 50-622
- saddle** Selle Royal Vivo Ergo
- sizes** Mixed 49-55cm  
Gent 52-58cm
- color** Lead-on-Black
- weight** 23.2KG  
(excl. battery 3.7KG)

- battery** Shimano STEPS BT-E8036 - 630Wh
- drive unit** Shimano STEPS DU-E6100 (60Nm - 250W)
- display** Shimano STEPS SC-E6100
- charger** Shimano STEPS EC-E6002



**SHIMANO STEPS**



## Travel Power Premium 630 S25E06TPSG

<b>frame</b>	Lite aluminium 6061 - In-tube battery - Tapered 1.5
<b>fork</b>	SR Suntour NCX32 Lock-out - Stealth
<b>group</b>	Shimano Deore Linkglide 1x10 11-43 - Shimano hydraulic disc brakes
<b>seatpost</b>	Supra Comp Line 27.2
<b>handlebar</b>	Supra Comp Line 70cm Flat
<b>stem</b>	Satori UP2+ Adjustable
<b>lock</b>	Axa Block XXL
<b>lights</b>	Trelock Veo 50 lux + AXA Juno - E-bike powered
<b>wheels</b>	Ryde DP19 + Shimano hubs
<b>tires</b>	Schwalbe Energizer Plus 50-622
<b>saddle</b>	Selle Royal Vivo Ergo
<b>sizes</b>	Mixed 49-55cm Gent 52-58cm
<b>color</b>	Shiny Alpine Grey
<b>weight</b>	23.8KG (excl. battery 3.7KG)

<b>battery</b>	Shimano STEPS BT-E8036 - 630Wh
<b>drive unit</b>	Shimano STEPS DU-E6100 (60Nm - 250W)
<b>display</b>	Shimano STEPS SC-E6100
<b>charger</b>	Shimano STEPS EC-E6002



SHIMANO  
STEPS



**Cintura Power N-7** S25E07CPMB

- frame** Lite aluminium 6061 - 2x butted - Tapered 1.5 - STEPS optimized
- fork** Supra superlite alloy - Tapered 1.5
- group** Shimano Nexus 7 - Shimano hydraulic disc brakes - Full Gates CDX belt drive
- seatpost** Supra Base Line
- handlebar** Uno Alloy
- stem** Satori UP2+ Adjustable
- lock** AXA Defender
- lights** AXA Blueline30 + AXA Juno - E-bike powered
- wheels** Ryde X-plorer + Shimano hubs
- tires** Schwalbe Road Cruiser Plus 47-622
- saddle** Selle Royal Essenza
- sizes** Mixed 49-55cm  
Gent 52-58cm
- color** Dark Brush
- weight** 21KG  
(excl. battery 2.6KG)

- battery** Shimano STEPS BT-E8010 - 504Wh
- drive unit** Shimano STEPS DU-E6100 (60Nm - 250W)
- display** Shimano STEPS SC-E5000
- charger** Shimano STEPS EC-E6002





## Travel Power V10 S25E05TPMG

<b>frame</b>	Lite aluminium 6061 - 2x butted - Tapered 1.5 - STEPS optimized V2
<b>fork</b>	Supra superlite alloy - Tapered 1.5
<b>group</b>	Shimano Deore 1x10 - Shimano hydraulic disc brakes
<b>seatpost</b>	Supra Base Line
<b>handlebar</b>	Supra Comp Line 68cm
<b>stem</b>	Satori UP2+ - Adjustable
<b>lock</b>	AXA Defender RL
<b>lights</b>	AXA Blueline30 + AXA Juno - E-bike powered
<b>wheels</b>	Ryde DP19 + Shimano hubs
<b>tires</b>	Schwalbe Road Cruiser Plus 47-622
<b>saddle</b>	Selle Royal Essenza
<b>sizes</b>	Mixed 49-55cm Gent 52-58cm
<b>color</b>	Matt Solid Grey
<b>weight</b>	19.6KG (excl. battery 2.6KG)

<b>battery</b>	Shimano STEPS BT-E8010 - 504Wh
<b>drive unit</b>	Shimano STEPS DU-E7000 (60Nm - 250W)
<b>display</b>	Shimano STEPS SC-E6100
<b>charger</b>	Shimano STEPS EC-E6002



SHIMANO  
STEPS



## RFC Premium Speed Disc

ROAD RACING SL - FULL CARBON 62MM

### WIDE AERODYNAMIC SUPER HIGH PROFILE

**RIMS** FULL CARBON CLINCHER 62MM HIGH, WIDTH 19IN -29OUT, UD SATIN FINISH, SHINY DECALS ON SATIN, TUBELESS READY | **SPOKES** - SAPIM CX-DELTA BLACK STRAIGHT PULL, FRONT 24 / REAR 24 | **NIPPLES** - SAPIM BRASS SECURE LOCK | **HUBS** - FRONT; SUPRA C526V1 CENTER-LOCK 12X100, REAR; SUPRA C527V1 CENTER-LOCK 12X142, STRAIGHT PULL, LOW DRAG SEALS, BODY 8/9/10/11/12SPEED SHIMANO (SRAM XDR BODY AVAILABLE) | **SKEWERS** - NO | **WEIGHT** - FRONT 740 / REAR 855



## RFC Premium SL Disc

ROAD RACING SL - FULL CARBON 35MM

### WIDE AERODYNAMIC HIGH PROFILE

**RIMS** FULL CARBON CLINCHER 35MM HIGH, WIDTH 19IN -28OUT, UD SATIN FINISH, SHINY DECALS ON SATIN, TUBELESS READY | **SPOKES** SAPIM CX-DELTA BLACK STRAIGHT PULL, FRONT 24 / REAR 24 | **NIPPLES** SAPIM BRASS SECURE LOCK | **HUBS** FRONT; SUPRA C526V1 CENTER-LOCK 12X100, REAR; SUPRA C527V1 CENTER-LOCK 12X142, STRAIGHT PULL, LOW DRAG SEALS, BODY 8/9/10/11/12SPEED SHIMANO (SRAM XDR BODY AVAILABLE) | **SKEWERS** NO | **WEIGHT** FRONT 625 / REAR 770



## RFC 50 Elite Disc

ROAD RACING SL - FULL CARBON 50MM

### WIDE AERODYNAMIC HIGH PROFILE

**RIMS** FULL CARBON CLINCHER 50MM HIGH, WIDTH 19IN-28OUT, UD SATIN FINISH, DECALS UNDER CLEAR COAT, TUBELESS READY | **SPOKES** SAPIM CX-DELTA BLACK, FRONT 24 / REAR 28 | **NIPPLES** SAPIM BRASS SECURE LOCK | **HUBS** FRONT; SUPRA C406V1 CENTER-LOCK 12X100, REAR; SUPRA C407V1 CENTER-LOCK 12X142, BODY 8/9/10/11/12SPEED SHIMANO (SRAM XDR BODY AVAILABLE) | **SKEWERS** NO | **WEIGHT** FRONT 690 / REAR 860



## RFC 35 Elite Disc

ROAD RACING SL - FULL CARBON 35MM

### WIDE AERODYNAMIC HIGH PROFILE

**RIMS** FULL CARBON CLINCHER 35MM HIGH, WIDTH 19IN -28OUT, UD SATIN FINISH, DECALS UNDER CLEAR COAT, TUBELESS READY | **SPOKES** SAPIM CX-DELTA BLACK, FRONT 24 / REAR 28 | **NIPPLES** SAPIM BRASS SECURE LOCK | **HUBS** FRONT; SUPRA C406V1 CENTER-LOCK 12X100, REAR; SUPRA C407V1 CENTER-LOCK 12X142, BODY 8/9/10/11/12SPEED SHIMANO (SRAM XDR BODY AVAILABLE) | **SKEWERS** NO | **WEIGHT** FRONT 670 / REAR 835





## RA Pro disc

ROAD RACING - ALUMINIUM

### MULTI-PERFORMANCE MEDIUM PROFILE

**RIMS** LIGHTWEIGHT ALUMINIUM CLINCHER 25MM HIGH, WIDTH 18,5IN-24OUT, ANODIZE BLACK FINISH | **SPOKES** PILLAR WIDE AERO BLACK, FRONT 24 / REAR 28 | **NIPPLES** - BRASS | **HUBS** FRONT; SUPRA KC3FV1 CENTER-LOCK 12X100, REAR; SUPRA K4HCV1 CENTER-LOCK 12X142, BODY 8/9/10/11/12SPEED SHIMANO | **SKEWERS** NO | **WEIGHT** FRONT 840 / REAR 995



## RA Comp DISC

ROAD RACING - ALUMINIUM

### MULTIPERFORMANCE MEDIUM PROFILE

**RIMS** LIGHTWEIGHT ALUMINIUM CLINCHER 25MM HIGH, WIDTH 18,5IN-24OUT, ANODIZE BLACK FINISH | **SPOKES** SAPIM BLACK, FRONT 28 / REAR 28 | **NIPPLES** BRASS | **HUBS** FRONT; SHIMANO RS470 CENTER-LOCK 12X100, REAR; SHIMANO RS470 CENTER-LOCK 12X142, BODY 8/9/10/11/12SPEED SHIMANO | **SKEWERS** NO | **WEIGHT** FRONT 910 / REAR 1090



## GA Elite TLR

GRAVEL RACING - ALUMINIUM

### MULTI-PERFORMANCE MEDIUM PROFILE

**RIMS** LIGHTWEIGHT ALUMINIUM CLINCHER 24MM HIGH, WIDTH 23IN-27OUT, ANODIZE BLACK FINISH, TUBELESS READY | **SPOKES** PILLAR AERO BLACK, FRONT 24 / REAR 28 | **NIPPLES** BRASS | **HUBS** FRONT; SUPRA KC3FV1 CENTER-LOCK 12X100, REAR; SUPRA K4HCV1 CENTER-LOCK 12X142, BODY 8/9/10/11/12SPEED SHIMANO | **SKEWERS** NO | **WEIGHT** FRONT 860 / REAR 1025



## RA ELITE

ROAD RACING - ALUMINIUM 30MM

### WIDE MULTIPERFORMANCE MEDIUM PROFILE

**RIMS** LIGHTWEIGHT ALUMINIUM CLINCHER 28MM HIGH, WIDTH 19IN-24OUT, MATT BLACK FINISH, CNC-SIDE, TUBELESS READY | **SPOKES** WIDE AERO BLACK, FRONT 24 / REAR 28 | **NIPPLES** BRASS POLYAX | **HUBS** FRONT; SEALED CARDRIDGE BEARING, REAR; NEW EASY-TO-SERVICE SEALED CARDRIDGE BEARING, BODY 8/9/10/11SPEED SHIMANO (CAMPA BODY AVAILABLE) | **SKEWERS** CR-MO | **WEIGHT** FRONT 775 / REAR 960

## GFC Elite TLR

GRAVEL RACING SL - FULL CARBON

### MULTI-PERFORMANCE HIGH PROFILE

**RIMS** FULL CARBON 40MM HIGH, WIDTH 25IN -30OUT, UD SATIN FINISH, MATT DECALS ON SATIN, HOOKLESS TUBELESS | **SPOKES** - PILLAR AERO BLACK, FRONT 24 / REAR 28 | **NIPPLES** - BRASS | **HUBS** - FRONT; SUPRA KC3FV1 CENTER-LOCK 12X100, REAR; SUPRA K4HCV1 CENTER-LOCK 12X142, BODY 8/9/10/11/12SPEED SHIMANO | **SKEWERS** - NO | **WEIGHT** - FRONT 745 / REAR 915



## MA Elite 23-TLR

MTB CROSSCOUNTRY - ALUMINIUM

### CROSSCOUNTRY RACING

**RIMS** 29ER SUPERLITE ALUMINIUM CLINCHER, 23INNER WIDTH, MATT BLACK FINISH, TUBELESS READY | **SPOKES** SAPIM RACE BLACK, FRONT 32 / REAR 32 | **NIPPLES** - SAPIM BRASS POLYAX | **HUBS** FRONT; SHIMANO MT410 15X110 BOOST, REAR; SHIMANO MT410 12X148 BOOST, MICROSPLINE 12SPEED | **SKEWERS** NO | **WEIGHT** FRONT 840 / REAR 1040



## MA Pro

MTB CROSSCOUNTRY - ALUMINIUM

### CROSSCOUNTRY RACING

**RIMS** 29ER ALUMINIUM CLINCHER, 21INNER WIDTH, MATT BLACK FINISH | **SPOKES** SAPIM BLACK, FRONT 32 / REAR 32 | **NIPPLES** SAPIM BRASS POLYAX | **HUBS** FRONT; SHIMANO MT410 15X110 BOOST, REAR; SHIMANO MT410 12X148 BOOST, MICROSPLINE 12SPEED | **SKEWERS** NO | **WEIGHT** FRONT 970 / REAR 1160



## MA Comp 500/200/100

MTB CROSSCOUNTRY - ALUMINIUM

### CROSSCOUNTRY SPORT

**RIMS** 29ER ALUMINIUM CLINCHER, 21INNER WIDTH, MATT BLACK FINISH | **SPOKES** SAPIM BLACK, FRONT 32 / REAR 32 | **NIPPLES** SAPIM BRASS POLYAX | **HUBS** FRONT; SHIMANO DISC CENTER-LOCK, REAR; SHIMANO DISC CENTER-LOCK | **SKEWERS** SHIMANO | **500** FRONT: MT200 100-QR / REAR: MT401 141-QR BOOST, 12SP MICRO-SPLINE **200** FRONT: MT200 100-QR / REAR: MT200 141-QR BOOST, 9/10SPEED **100** FRONT: M3050 100-QR / REAR: M3050 135-QR - 8/9/10/11SPEED





**NEXT LEVEL INTEGRATION | SUPRA COMBO AERO**

For the Giulia Supremo we created the Combo Aero. Using our existing adapters and puzzle spacers it is purpose built for full internal cablerouting. The smooth shapes are more aerodynamic than its predecessor the Combo Integrale. It is also more ergonomic. The underside is a big continuous tunnel which allows cables to be guided super easy. Changing bars can be done without detaching the brakehose from the lever. To keep things tidy there is a cover which mounts easy and allows the slideable Garmin-holder or the Raceday FI hide-my-bell to be mounted.

The bend has been reshaped. Creating a dual flare, so the bar is more narrow at the hoods than at the outers and the slight outward position of the lower part gives more room for the wrist while sprinting.

The topcap can be replaced by any standard round spacer, so it's possible to keep some additional length to your steerer, to finetune your position. Finishing off with 3D grip bumps on top of the bars for additional grip the Combo AERO is ready to go.

It's offered in 4 sizes all with a nicely compact bend (75mm reach, 126mm drop).



SMOOTH SHAPES



3D GRIP BUMPS



DUAL FLARED BEND



DUAL FLARED BEND



SMOOTH SHAPES



TUNNEL + COVER



## SUPRA COMBO INTEGRALE

### NEXT LEVEL INTEGRATION | SUPRA COMBO INTEGRALE

To further personalize your bike we created the Combo Integrale. Using a special Evo adapter and Evo spacer-kit it integrates neatly into the Giulia frames. But it can be used on other bikes as well. To fit to bikes with standard headtubes (+- 46mm wide) we offer the "combo-to-standard adapter". This adapter is also compatible with the Evo spacer-kit. The latest "Integrale" version also allows for full internal cablerouting as used on our Giulia GF, Giulia Evo Integrale and Giulia Supremo. But it is still backwards compatible with cables running outside of the headtube. For when running full internal cables we developed a new Integrale adapter + base spacer and puzzle spacers. So you can change riding-height swiftly.

The angular styled full carbon 1-piece bar-stem is easy in everyday life. It has got removable cover plates to keep maintenance on your bike more easy. The flat top ensures a clean and tidy outlook when riding your bike.

The Combo comes with an Integrated Topcap and a special Exit-hole Topcap, so you can ride with a longer steerer before cutting the steerer to the perfect length. We also offer a slideable Garmin-holder and an a Raceday FI hide-my-bell version of the Garmin-holder.

It's offered in 5 sizes (90x40 - 100x42 \* - 110x42 - 120x44 - 130x44) all with a nicely compact bend (75mm reach, 126mm drop, 2 ° flare) and at \* 385gram it is lightweight. It's compatible with the Shimano RS-910 Di2 junction.



INTEGRATED TOPCAP



REMOVEABLE COVER PLATES



GARMIN HOLDER



HIDE MY BELL



COVERCAP TO GF



COMBO-TO-STANDARD ADAPTER



EXIT-HOLE TOPCAP



EVO ADAPTER



EVO SPACERS 5 & 10MM



PUZZLE SPACER



CS25SSC3  
Sensar Bioracer  
Jersey Icon Luxe -  
Off white



CS25SSC2  
Sensar Bioracer  
Jersey Icon Luxe -  
Fade-to-Purple



CS25BSBB  
Bioracer  
BIBshort  
Epic



CS25SSC1  
Sensar Bioracer  
Jersey Icon Luxe -  
Fade-to-Grey

# SENSA

Intersens Bikes & Parts BV  
Bedrijvenpark Twente 170  
NL-7602 KE Almelo  
The Netherlands

[info@sensabikes.com](mailto:info@sensabikes.com)  
[www.sensabikes.com](http://www.sensabikes.com)  
[facebook.com/sensabikesnl](https://facebook.com/sensabikesnl)  
[instagram.com/sensabikesnl](https://instagram.com/sensabikesnl)



**Disclaimer** No rights can be claimed from the information in this brochure. Although all is done to make the information as complete and correct as possible, no rights can be derived from the information presented in this brochure. Weights are based on the presented models without pedals and can deviate. The frame sizes are measured center-top. See our website for full information on the geometries. Prices and specifications can be changed without prior notice and can deviate per country.